



User Manual

English

APC Smart-UPS[®] RT – UXI/UXICH

3000/5000/6000 VA 220/230/240 VAC

Tower/Rack-Mount 3U

Uninterruptible Power Supply

990-1392D 12/2005

Introduction

The APC Smart-UPS® RT is a high-performance, uninterruptible power supply (UPS) that provides protection for electronic equipment from utility power blackouts, brownouts, sags and surges. The UPS filters small utility line fluctuations and isolates electronic equipment from large disturbances by internally disconnecting from utility line power. The UPS provides continuous power from the internal battery until utility power returns to safe levels or the battery is fully discharged.

INSTALLATION

Read the Safety Instruction sheet before installing the UPS.

Unpacking

Inspect the UPS upon receipt. Notify the carrier and dealer if there is damage.

The packaging is recyclable; save it for reuse or dispose of it properly.

Check the package contents:

- UPS
- Front bezel
- Literature kit containing:
 - Product documentation, Safety Guide, and Warranty information
 - Smart-UPS RT User Manuals CD
 - Software CD
- Ground wire
- Serial cable
- Battery cable assembly
- 3000 VA XLI models: three output power cords, two input power cords
- 5000/6000 VA XLI models: six output power cords, Network Management Card documentation

Specifications

TEMPERATURE OPERATING STORAGE	32° to 104° F (0° to 40° C) 5° to 113° F (-15° to 45° C) charge the UPS battery every six months	This unit is intended for indoor use only. Select a location sturdy enough to handle the weight. Do not operate the UPS where there is excessive dust or the temperature and humidity are outside the specified limits. Ensure that the air vents on the front and rear of the UPS are not blocked.
MAXIMUM ELEVATION OPERATING STORAGE	10,000 ft (3,000 m) 50,000 ft (15,240 m)	
HUMIDITY	0 to 95% relative humidity	
WEIGHT UPS UPS WITH PACKAGING	120 lbs (55 kg) 140 lbs (64 kg)	

ATTACH THE BEZEL TO THE UPS



5000/6000 VA XLI MODELS ONLY: HARDWIRING INSTRUCTIONS

- Wiring must be performed by a qualified electrician.
 - Adhere to all national and local electrical codes.
 - Install a high magnetic 30/32 A utility circuit breaker
 - Use #10 AWG gauge (5sq. mm) wire.
1. Switch the utility circuit breaker OFF.
 2. Remove the input access panel.
 3. Remove circular knockout.

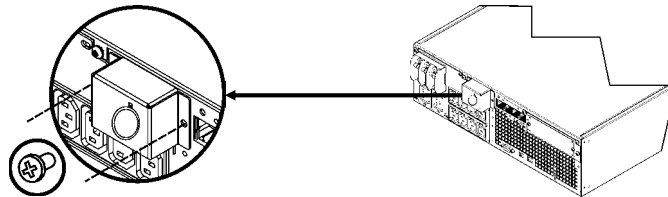

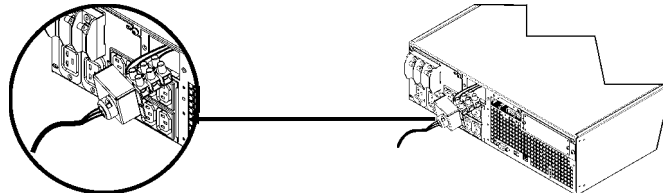

4. Run #10 AWG gauge (5sq. mm) wire through the access panel, and connect the wires to the terminal block (Green: Ground, Brown: Hot, Blue: Neutral). Use an appropriate strain relief (not included).

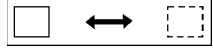

5. Replace the access panel.

BASIC CONNECTORS

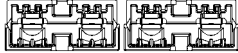
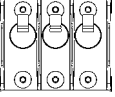
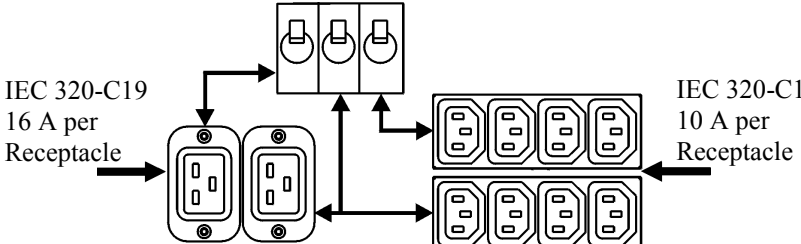
 <p>serial com</p>	<p>Power management software and interface kits can be used with the UPS. Use only cables approved by APC. Any other interface cable will be incompatible with the UPS connector.</p>
 <p>normal bypass</p>	<p>Manual bypass enables the user to manually put connected equipment into bypass mode.</p>
 <p>EPO terminal</p>	<p>Emergency Power Off terminal allows the user to connect the UPS to the central EPO system.</p>
 <p>TVSS screw</p>	<p>The UPS features a transient voltage surge-suppression (TVSS) screw for connecting the ground lead on surge suppression devices such as telephone and network line protectors. When connecting grounding cable, disconnect the unit from the utility power outlet.</p>
 <p>external battery pack connector</p>	<p>External battery packs must be connected to these connectors located on the rear panel of the unit.</p>
<p><i>5000/6000 VA models</i></p>  <p>output circuit breakers</p>	 <p>IEC 320-C19 16 A per Receptacle</p> <p>IEC 320-C13 10 A per Receptacle</p>

CONNECT THE EXTERNAL BATTERIES

Battery Safety

Read and adhere to the following warnings when installing or servicing the external batteries. Failure to observe these warnings may result in serious injury, death or damage to the equipment.

<p>WARNINGS</p> 	<ul style="list-style-type: none">• Do not attempt to install or service external batteries alone. A qualified electrician should perform the installation and servicing of external batteries.• Disconnect charging source(s) BEFORE connecting or disconnecting battery terminals.• External batteries may retain lethal voltages after power has been disconnected and all switches are off.• Use extreme caution when making terminal connections. Do not allow cables to touch anything except the intended terminal.
<p>PRACTICES</p>	<p>Always wear: Goggles or face shields Acid-resistant, insulated gloves Protective aprons Protective overshoes or rubber boots</p> <p>Always Use: Insulated tools Rubber mats to cover batteries during servicing Rubber mats or rubber stands on the floor Adequate lifting devices</p> <p>Remove: Watches, rings, and other metal objects from your body</p>
<p>PRECAUTIONS</p>	<ul style="list-style-type: none">• To avoid static build-up, service personnel should establish a grounding contact prior working on batteries.• Do not lay tools or metal parts on top of batteries.• Lead-acid batteries contain hazardous, toxic materials.<ul style="list-style-type: none">▪ Do not open, alter or mutilate batteries. Internal materials may be harmful to the skin and eyes.▪ Do not dispose of batteries in a fire. There is danger of explosion.• Handle, transport and recycle batteries in accordance with local codes and regulations.

APC BATTERY SOLUTION

See the APC Web site www.apc.com, or contact your APC dealer for information regarding the APC external battery pack.

THIRD PARTY BATTERY SOLUTION

Batteries must be Sealed Lead-Acid type. Use 50 A, 250 VDC fuses with an Interrupt rating of $\geq 20,000$ A.

Ensure that the external batteries are wired prior to connecting the batteries to the UPS.

If using a non-APC battery pack, a 192 V battery string should be wired to the UPS using the enclosed battery cable assembly.

Connect the Ground and Wire the Battery System

1. Connect the ground wire (included), to the battery enclosure ground and the TVSS screw on the back of the UPS.
2. Cut off one of the connectors on the cable revealing positive and negative wires.



3. Connect the positive (red), and negative (black) wires to the positive and negative terminals on the external battery system. Ensure that the proper polarities are connected.
4. Plug the cable connector into one of the battery connector receptacles on the back of the UPS. Either receptacle may be used.

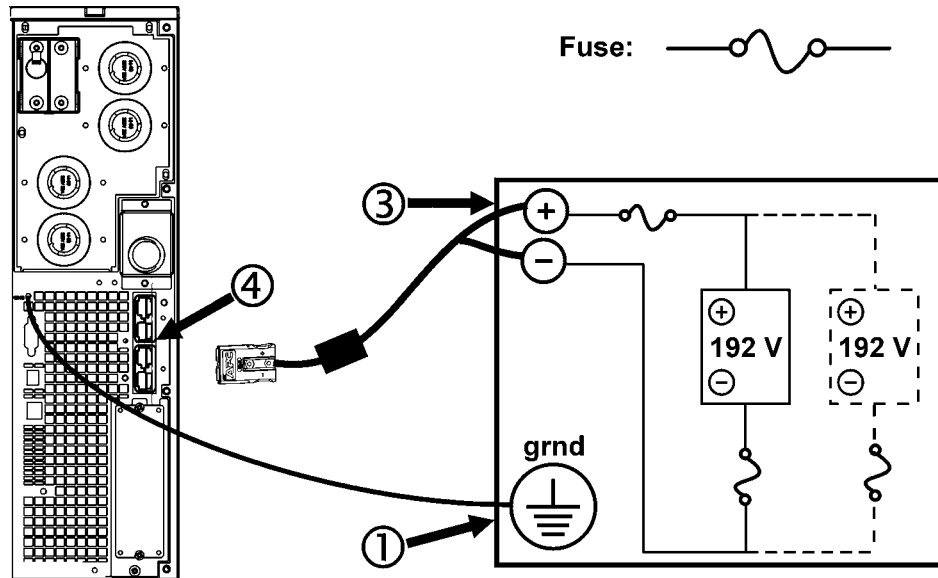

CONNECT EQUIPMENT AND POWER TO THE UPS

1. Connect equipment to the UPS.
2. *3000 VA models:* Using a power cord, plug the UPS into a two-pole, three-wire, grounded receptacle only.

Avoid using extension cords.

3. Turn on all connected equipment. To use the UPS as a master ON/OFF switch, ensure all connected equipment is switched ON. The equipment will not be powered until the UPS is turned on.
4. Switch the utility circuit breaker on.
5. To power up the UPS press the  button on the front panel.
 - The UPS battery charges when it is connected to utility power. Allow at least 24 hours for the batteries to fully charge prior to connecting equipment to the UPS.
6. For additional computer system security, install PowerChute[®] *Server Smart-UPS* monitoring software.

PROGRAM THE UPS FOR THE NUMBER OF EXTERNAL BATTERIES

Option1: Using PowerChute[®] *Business Edition*

1. Install the software per the instructions on the CD. After rebooting the computer, access the PowerChute *Business Edition* console.
2. Select the appropriate host name.
3. Select Device Properties from the view menu.
4. Select Battery Status.
5. Locate the Battery Packs field and type in the correct number of external batteries.
NOTE: The default setting of 1 = 1 external battery (1 = 1920 VAh; 192 V x 10 Ah),
2 = 2 external batteries (2 = 3840 VAh) etc.
6. Press APPLY
7. Close the dialogue box.

Option 2: Terminal Mode

Refer to *Terminal Mode* section in this manual.

OPERATION

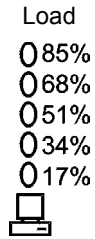



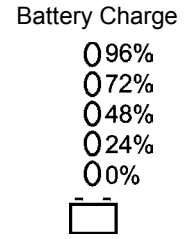
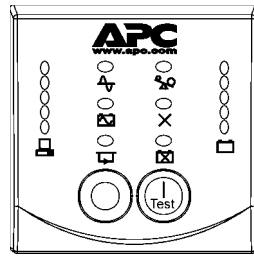

SMART-UPS RT FRONT DISPLAY



Indicator	Description
Online 	The Online LED illuminates when the UPS is drawing utility power and performing double conversion to supply power to connected equipment.
On Battery 	The UPS is supplying battery power to the connected equipment.
Bypass 	The Bypass LED illuminates indicating that the UPS is in bypass mode. Utility power is sent directly to connected equipment during bypass mode operation. Bypass mode operation is the result of an internal UPS fault, an overload condition or a user initiated command either through an accessory or the manual bypass switch. Battery operation is not available while the UPS is in bypass mode. Refer to <i>Troubleshooting</i> in this manual.
Fault 	The UPS detects an internal fault. Refer to <i>Troubleshooting</i> in this manual.
Overload 	An overload condition exists. See <i>Troubleshooting</i> .
Replace Battery 	The battery is disconnected or must be replaced. See <i>Troubleshooting</i> .

Feature	Function
Power On 	Press this button to turn on the UPS. (See below for additional capabilities.)
Power Off 	Press this button to turn off the UPS.

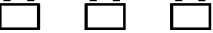
Feature	Function
Cold Start 	This is not a normal condition. When there is no utility power and the UPS is off, press and hold the  button to power up the UPS and connected equipment. The UPS will emit two beeps. During the second beep, release the button.
Self-Test	Automatic: The UPS performs a self-test automatically when turned on, and every two weeks thereafter (by default). During the self-test, the UPS briefly operates the connected equipment on battery. Manual: Press and hold the  button for a few seconds to initiate the self-test.

Diagnostic Utility Voltage 220V 230V 240V 0256 0266 0276 0238 0248 0258 0219 0229 0239 0200 0210 0220 0181 0192 0202 	The UPS has a diagnostic feature that displays the utility voltage. Plug the UPS into the normal utility power. The UPS starts a self-test as part of this procedure. The self-test does not affect the voltage display. Press and hold the  button to view the utility voltage bar graph display. After a few seconds the five-LED, <i>Battery Charge</i>  display on the right of the front panel shows the utility input voltage. Refer to the figure at left for the voltage reading (values are not listed on the UPS). The display indicates the voltage is between the displayed value on the list and the next higher value.
--	--

BATTERY OPERATION

The UPS switches to battery operation automatically if the utility power fails. While running on battery, an alarm beeps four times every 30 seconds.

Press the  button to silence this alarm. If the utility power does not return, the UPS continues to supply power to the connected equipment until the battery is fully discharged.

When 2 minutes of run time remain the UPS emits a continuous beeping. If PowerChute is not being used, files must be manually saved and the computer must be turned off before the UPS fully discharges the battery.

The UPS battery life differs based on usage and environment. Refer to www.apc.com for on battery runtimes.

USER CONFIGURABLE ITEMS

NOTE: SETTINGS ARE MADE THROUGH SUPPLIED POWERCHUTE SOFTWARE OPTIONAL SMART SLOT ACCESSORY CARDS OR TERMINAL MODE.			
<i>FUNCTION</i>	<i>FACTORY DEFAULT</i>	<i>USER SELECTABLE CHOICES</i>	<i>DESCRIPTION</i>
Automatic Self-Test	Every 14 days (336 hours)	Every 7 days(168 hours), 14 days (336 hours) On Startup Only, No Self-Test	Set the interval at which the UPS will execute a self-test.
UPS ID	UPS_IDEN	Up to eight characters to define the UPS	Uniquely identify the UPS, (i.e. server name or location) for network management purposes.
Date of Last Battery Replacement	Manufacture Date	Date of Battery Replacement mm/dd/yy	Reset this date when you replace the battery module.
Minimum Capacity Before Return from Shutdown	0 percent	0, 15, 25, 35, 50, 60, 75, 90 percent	Following a low-battery shutdown, the batteries will be charged to the specified percentage before powering connected equipment.
Alarm Delay After Line Failure	5 second delay	5 or 30 second delay At Low Battery Never	Mute ongoing alarms or disable all alarms permanently.
Shutdown Delay	20 seconds	0, 20, 60, 120, 240, 480, 720, 960 seconds	Set the interval between the time when the UPS receives a shutdown command and the actual shutdown.
Duration of Low Battery Warning.	2 minutes PowerChute software provides automatic, unattended shutdown when approximately 2 minutes of battery operated runtime remains.	2, 5, 7, 10, 12, 15, 18, 20 minutes	The low battery warning beeps are continuous when two minutes of run time remain. Change the warning interval default to a higher setting if the operating system requires a longer interval for shutdown.
Synchronized Turn-on Delay	0 seconds	0, 20, 60, 120, 240, 480, 720, 960 seconds	The UPS will wait the specified time after the return of utility power before turn-on (to avoid branch circuit overload).

NOTE: SETTINGS ARE MADE THROUGH SUPPLIED POWERCHUTE SOFTWARE OPTIONAL SMART SLOT ACCESSORY CARDS OR TERMINAL MODE.			
<i>FUNCTION</i>	<i>FACTORY DEFAULT</i>	<i>USER SELECTABLE CHOICES</i>	<i>DESCRIPTION</i>
High Bypass Point	+10% of output voltage setting	+5%, +10%, +15%, +20%	Maximum voltage that the UPS will pass to connected equipment during internal bypass operation.
Low Bypass Point	-30% of output voltage setting	-15%, -20%, -25%, -30%	Minimum voltage that the UPS will pass to connected equipment during internal bypass operation.
Output Voltage	230 VAC	220, 225, 230, 240 VAC	Allows the user to select the output voltage.
Output Frequency	Automatic 50 ± 3 Hz or 60 ± 3 Hz	Automatic 50 ± 3 Hz, 50 ± 0.1 Hz 60 ± 3 Hz 60 ± 0.1 Hz	Sets the allowable UPS output frequency. Whenever possible, the output frequency tracks the input frequency.
Number of Batteries	1	Number of Connected Batteries	Defines the number of connected batteries for proper run time prediction. Default setting of 1 = 1920 VAh (192 V x 10 Ah) Setting of 2 = 3840 VAh, etc.

CONNECT THE EPO (EMERGENCY POWER OFF) OPTION

The output power can be disabled in an emergency by closing a switch connected to the EPO.

Adhere to national and local electrical codes when wiring the EPO.

Wiring must be performed by a qualified electrician.

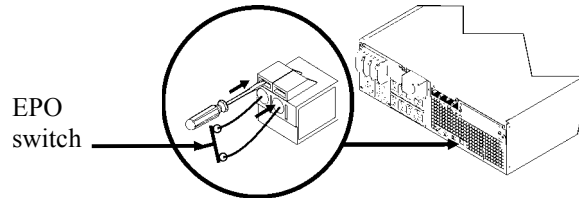

The EPO switch is internally powered by the UPS for use with non-powered switch circuit breakers.

The EPO circuit is considered a Class 2 circuit, (UL, CSA standards) and a SELV circuit (IEC standard).

Both Class 2 and SELV circuits must be isolated from all primary circuitry. Do not connect any circuit to the EPO terminal block unless it can be confirmed that the circuit is Class 2 or SELV.

If circuit standard cannot be confirmed, use a contact closure switch.

Use one of the following cable types to connect the UPS to the EPO switch:

- CL2: Class 2 cable for general use
- CL2P: Plenum cable for use in ducts, plenums, and other spaces used for environmental air.
- CL2R: Riser cable for use in a vertical run in a floor-to-floor shaft.
- CLEX: Limited use cable for use in dwellings and for use in raceways.
- For installation in Canada: Use only CSA certified, type ELC (extra-low voltage control cable).
- For installation in other countries: Use standard low-voltage cable in accordance with local regulations.

TERMINAL MODE TO CONFIGURE UPS PARAMETERS

3000/5000 VA models:

Terminal Mode is a menu driven interface that enables enhanced configuration of the UPS.

Connect the serial cable from the computer to the serial com connector on the back of the UPS.

1. **EXIT** the PowerChute *Business Edition* using the following steps:
 - From the Desktop, go to **Start => Settings => Control Panel => Administrative Tools => Services**.
 - Select **APC PCBE Server** and **APC PCBE Agent** – right click the mouse and select **Stop**.
2. Open a terminal program. Example: HyperTerminal
 - From the Desktop, go to **Start => Programs => Accessories => Communication =>HyperTerminal**.
3. Double-click on the **HyperTerminal** icon.
 - Follow the prompts to choose a name and select an icon. Disregard the message, “...must install a modem,” if it is displayed. Click OK.
 - Select the **COM** port that is connected to your UPS. The port settings are:
 - ✓ *bits per second - 2400*
 - ✓ *data - bits 8*
 - ✓ *parity - none*
 - ✓ *stop bit - 1*
 - ✓ *flow control - none*
 - Press ENTER
4. Example for setting the number of external battery packs:

Once the blank terminal window is open, follow these steps to enter the number of battery packs:

 - Press ENTER to initiate terminal mode. Follow the prompts:
 - Press 1 to modify UPS Settings. Press e (or E) to modify the number of battery packs. ENTER the number of external battery packs.
Number of packs: 1= 1920 VAh, 2 = 3840 VAh, 3 = 5760 VAh, etc.
 - Press ENTER.
 - Follow the prompts.
5. Exit the terminal program.

MAINTENANCE AND SERVICE INFORMATION

Battery Replacement

See your dealer or contact APC at the Web site, www.apc.com for information on replacement battery modules.

Service

If the UPS requires service do not return it to the dealer. Follow these steps:

1. Review the problems discussed in the *Troubleshooting* section of this manual to eliminate common problems.
2. If the problem persists, contact APC Customer Support through the APC Web site, www.apc.com.
 - Note the model number of the UPS, the serial number located on the back of the unit, and the date purchased. If you call APC Customer Support, a technician will ask you to describe the problem and attempt to solve it over the phone. If this is not possible, the technician will issue a Returned Material Authorization Number (RMA#).
 - If the UPS is under warranty, repairs are free.
 - Procedures for servicing or returning products may vary internationally. Refer to the APC Web site for country specific instructions.
3. Pack the UPS in its original packaging.
 - If the original packing is not available, refer to the APC Web site, www.apc.com, for information about obtaining a new set.
 - Pack the UPS properly to avoid damage in transit. Never use Styrofoam beads for packaging. Damage sustained in transit is not covered under warranty.





Always DISCONNECT THE BATTERY(S) before shipping in compliance with U.S. Department of Transportation (DOT) and IATA regulations.

4. Mark the RMA# on the outside of the package.

Return the UPS by insured, prepaid carrier to the address given to you by Customer Service.

TROUBLESHOOTING

Use the table below to solve minor installation and operation problems. Refer to the APC Web site, www.apc.com, for assistance with complex UPS problems.

PROBLEM AND POSSIBLE CAUSE	SOLUTION
UPS WILL NOT TURN ON	
Battery not connected properly.  button not pushed. UPS not connected to utility power supply. Very low or no utility voltage.	Check that the battery connectors are fully engaged. Press the  button once to power the UPS and the connected equipment. Check that the power cable from the UPS to the utility power supply is securely connected at both ends. Check the utility power supply to the UPS by plugging in a table lamp. If the light is very dim, have the utility voltage checked.
UPS WILL NOT TURN OFF	
 button not pushed. Internal UPS fault.	Press the  button once to turn the UPS off. Do not attempt to use the UPS. Unplug the UPS and have it serviced immediately.
UPS BEEPS OCCASIONALLY	
Normal UPS operation when running on battery.	None. The UPS is protecting the connected equipment.
UPS DOES NOT PROVIDE EXPECTED BACKUP TIME	
The UPS battery(s) are weak due to a recent outage or battery(s) are near the end of their service life.	Charge the battery(s). Batteries require recharging after extended outages. They wear faster when put into service often or when operated at elevated temperatures. If the battery(s) are near the end of their service life, consider replacing the battery(s) even if the <i>Replace Battery</i> LED is not illuminated.
FRONT PANEL LEDs FLASH SEQUENTIALLY	
The UPS has been shut down remotely through software or an optional accessory card.	None. The UPS will restart automatically when utility power returns.
ALL LEDs ARE OFF AND THE UPS IS PLUGGED INTO A WALL OUTLET	
The UPS is shut down and the battery is discharged from an extended outage.	None. The UPS will return to normal operation when the power is restored and the battery has a sufficient charge.
BYPASS AND OVERLOAD LEDs ILLUMINATE, UPS EMITS A SUSTAINED ALARM TONE	
The UPS is overloaded	The connected equipment exceeds the specified “maximum load” as defined in <i>Specifications</i> on the APC Web site, www.apc.com . The alarm remains on until the overload is removed. Disconnect nonessential equipment from the UPS to eliminate the overload condition.

PROBLEM AND POSSIBLE CAUSE	SOLUTION
BYPASS LED ILLUMINATES	
The bypass switch has been turned on manually or through an accessory.	If bypass is the chosen mode of operation, ignore the illuminated LED. If bypass is not the chosen mode of operation move the bypass switch on the back of the UPS, to the <i>normal</i> position.
FAULT AND OVERLOAD LEDs ILLUMINATE, UPS EMITS A SUSTAINED ALARM TONE	
The UPS has ceased sending power to connected equipment.	The connected equipment exceeds the specified “maximum load” as defined in <i>Specifications</i> on the APC Web site, www.apc.com . Disconnect nonessential equipment from the UPS to eliminate the overload condition. Press the OFF button, then the ON button to restore power to connected equipment.
FAULT LED ILLUMINATES	
Internal UPS fault.	Do not attempt to use the UPS. Turn the UPS off and have it serviced immediately.
REPLACE BATTERY LED ILLUMINATES	
Replace Battery LED flashes and short beep is emitted every two seconds to indicate the battery is disconnected. Weak battery. Failure of a battery self-test.	Check that the battery connectors are fully engaged. Allow the battery to recharge for 24 hours. Then, perform a self-test. If the problem persists after recharging, replace the battery. The UPS emits short beeps for one minute and the <i>Replace Battery</i> LED illuminates. The UPS repeats the alarm every five hours. Perform the self-test procedure after the battery has charged for 24 hours to confirm the <i>Replace Battery</i> condition. The alarm stops and the LED clears if the battery passes the self-test.
UPS OPERATES ON BATTERY ALTHOUGH LINE VOLTAGE EXISTS	
Very high, low, or distorted line voltage. Inexpensive fuel powered generators can distort the voltage.	Move the UPS to a different outlet on a different circuit. Test the input voltage with the utility voltage display.
DIAGNOSTIC UTILITY VOLTAGE	
All five LEDs are illuminated	The line voltage is extremely high and should be checked by an electrician.
There is no LED illumination	If the UPS is plugged into a properly functioning utility power outlet, the line voltage is extremely low.
ONLINE LED	
There is no LED illumination	The UPS is running on battery, or it is not turned on.
The LED is blinking	The UPS is running an internal self-test.

REGULATORY AND WARRANTY INFORMATION

Regulatory Agency Approvals and Radio Frequency Warnings

220, 230, 240 V MODELS

This equipment has been tested and found to comply with the limits for a Class A digital device, pursuant to Part 15 of the FCC rules. These limits are designed to provide reasonable protection against harmful interference when the equipment is operated in a commercial environment. This equipment generates, uses, and can radiate radio frequency energy. If it is not installed and used in accordance with the instruction manual, it may cause harmful interference to radio communications. Operation of this equipment in a residential area is likely to cause harmful interference, in which case users will be required to take whatever measures may be necessary to correct the interference at their own expense.

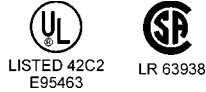

警告使用者：
這是A類的資訊產品，在居住的
環境中使用時，可能會造成射頻
干擾，在這種情況下，使用者會
被要求採取某些適當的對策。

この装置は、情報処理装置等電波障害自主規制協議会(VCCI)の基準に基づいたクラスA情報技術装置です。この装置を家庭環境で使用すると電波妨害を引き起こすことがあります。この場合には使用者が適切な対策を講ずるよう要求されることがあります。 VCCI-A

Limited Warranty

American Power Conversion (APC) warrants its products to be free from defects in materials and workmanship for a period of two years from the date of purchase. Its obligation under this warranty is limited to repairing or replacing, at its own sole option, any such defective products. To obtain service under warranty you must obtain a Returned Material Authorization (RMA) number from customer support. Products must be returned with transportation charges prepaid and must be accompanied by a brief description of the problem encountered and proof of date and place of purchase. This warranty does not apply to equipment that has been damaged by accident, negligence, or misapplication or has been altered or modified in any way. This warranty applies only to the original purchaser who must have properly registered the product within 10 days of purchase.

EXCEPT AS PROVIDED HEREIN, AMERICAN POWER CONVERSION MAKES NO WARRANTIES, EXPRESSED OR IMPLIED, INCLUDING WARRANTIES OF MERCHANTABILITY AND FITNESS FOR A PARTICULAR PURPOSE. Some states do not permit limitation or exclusion of implied warranties; therefore, the aforesaid limitation(s) or exclusion(s) may not apply to the purchaser.

EXCEPT AS PROVIDED ABOVE, IN NO EVENT WILL APC BE LIABLE FOR DIRECT, INDIRECT, SPECIAL, INCIDENTAL, OR CONSEQUENTIAL DAMAGES ARISING OUT OF THE USE OF THIS PRODUCT, EVEN IF ADVISED OF THE POSSIBILITY OF SUCH DAMAGE. Specifically, APC is not liable for any costs, such as lost profits or revenue, loss of equipment, loss of use of equipment, loss of software, loss of data, costs of substitutes, claims by third parties, or otherwise.

Declaration of Conformity



EC Declaration of Conformity

2005

Date of product declaration

We, the undersigned, declare under our sole responsibility that the equipment specified below conforms to the following standards and directives:

Standards to Which Conformity Declared:	EN55024; EN62040-1; EN61000-3-2, 3-3, 4-2, 4-3, 4-4, 4-5, 4-6, 4-8, 4-11; EN60950-1; IEC60950-1	
Application of Council Directives:	73/23/EEC; 93/68/EEC	
Type of Equipment:	Uninterruptible Power Supply	
Model Numbers:	SURT3000XLI; SURT3000UXI; SURT5000XLI; SURT5000UXI; SURT6000XLI; SURT6000UXI	
Manufacturers:		
American Power Conversion Ballybritt Business Park Galway, Ireland	American Power Conversion 2nd Street PEZA, Cavite Economic Zone Rosario, Cavite Philippines	APC (Suzhou) UPS Co., Ltd 339 Suhong Zhong Lu Suzhou Industrial Park Suzhou Jiangsu 215021 P. R. China
American Power Conversion Breaffy Rd. Castlebar Co Mayo, Ireland	American Power Conversion Lot 10, Block 16, Phase 4 PEZA, Rosario, Cavite Philippines	APC Brasil LTDA. AI. Xingu, 850 Barueri Alphaville/Sao Paulo 06455-030 Brazil
American Power Conversion 132 Fairgrounds Rd. West Kingston, RI 02892 USA	American Power Conversion Lot 3, Block 14, Phase 3 PEZA, Rosario, Cavite Philippines	
American Power Conversion 1600 Division Rd. West Warwick, RI 02892 USA	APC India Pvt. Ltd. 187/3, 188/3, Jigani Industrial Area, Jigani Bangalore, 562106 Karnataka India	
American Power Conversion 40 Catamore Blvd. East Providence, RI 02914 USA		
Importer:	American Power Conversion (A. P. C.) b. v. Ballybritt Business Park Galway, Ireland	
Place:	Galway, Ireland	Ray S. Ballard, Managing Director, Europe

 5 Jan 05

APC Worldwide Customer Support

Customer support for this or any other APC product is available at no charge in any of the following ways:

- Refer to the APC Web site to access documents in the APC Knowledge Base and to submit customer support requests.
 - **www.apc.com** (Corporate Headquarters)
Connect to localized APC Web sites for specific countries, each of which provides customer support information.
 - **www.apc.com/support/**
Global support searching APC Knowledge Base and using e-support.
- Contact an APC Customer Support center by telephone or e-mail.
Local, country-specific centers:
go to **www.apc.com/support/contact** for information.

Contact the APC representative or other distributor from whom you purchased your APC product for information on how to obtain local customer support.

Entire contents copyright 2005 American Power Conversion Corporation. All rights reserved. Reproduction in whole or in part without permission is prohibited.

APC, the APC logo, Smart-UPS, and PowerChute are trademarks of American Power Conversion Corporation. All other trademarks, product names, and corporate names are the property of their respective owners and are used for informational purposes only.